

CONSTRUCTION EQUIPMENT

Simmler *Vermietung
Verkauf
Reparatur*
Baumaschinen

SUNWARD
INNOVATION LEADS TO VALUE

MEDIUM EXCAVATORS
SWE 155F | SWE 155UF | SWE 155UF-2PB

Engine Power: **90 – 93 kW**

Machine Weight: **15 700 – 17 000 kg**



TECHNICAL PARAMETERS

		SWE 155F	SWE 155UF	SWE 155UF-2PB
TYPE OF CAB		Cab	Cab	Cab
BUCKET CAPACITY		0.61 m ³	0.61 m ³	0.61 m ³
BUCKET WIDTH, STD.		940 mm	940 mm	940 mm
MACHINE WEIGHT		15 600 kg	16 500 kg	17 000 kg
DIMENSIONS	Boom Length	4 600 mm	4 600 mm	1 980 mm + 2 820mm
	Arm Length	2 500 mm	2 500 mm	2 500 mm
	Overall dimension (L × W × H)	8 250 * 2 600 * 2 950 mm	7 345 * 2 600 * 2 950 mm	8 250 * 2 600 * 2 950 mm
	A Total Length	8 250 mm	7 345 mm	8 250 mm
	B Total Height	2 850 mm	2 950 mm	2 950 mm
	C Total Width	2 600 mm	2 600 mm	2 600 mm
	D Counterweight ground clearance	940 mm	935 mm	935 mm
	E Mini ground clearance	410 mm	410 mm	410 mm
	F Tail swing radius	2355 mm	1490 mm	1490 mm
	G Track length on the ground	3 000 mm	3 000 mm	3 000 mm
	H Track Length	3 765 mm	3 760 mm	3 760 mm
	I Track gauge	2 000 mm	2 000 mm	2000 mm
	J Undercarriage Width	2 600 mm	2 600 mm	2 600 mm
	K Trackshoe width	600 mm	600 mm	600 mm
L Cab height	2 850 mm	2 885 mm	2 885 mm	
M Height of engine hood	2 145 mm	2 600 mm	2 600 mm	
N Width of turntable	2 490 mm	2 490 mm	2 490 mm	
SPECIFICATION	Operating weight	15 600 kg	16 500 kg	17 000 kg
	Bucket capacity	0.61 m ³	0.61 m ³	0.61 m ³
ENGINE	Brand	Cummins		
	Emmission Rating	EU Stage V		
	Model	QSF3.8		
	Type	4 Stroke, Turbo Charged, Air cooled, Direct In		
	Power	93 kW/2 200 rpm	90 kW/2200 rpm	90 kW/2200 rpm
	Max Output Torque	500 Nm/1500 rpm	501 Nm/1500 rpm	502 Nm/1 500 rpm
	Displacement	3.8 L		
HYDRAULIC SYSTEM	Hydraulic pump type	Variable Piston Pump	Variable Piston Pump	Variable Piston Pump
	Max displacement of hydraulic pump	2×126.4 L/min	300 L/min	300 L/min
	Hydraulic pressure of hydraulic pump	34.3 Mpa	31.4/34.3 Mpa	31.4/34.3 Mpa
	Pilot pump	Gear Pump	Gear Pump	Gear Pump
	Max displacement of pilot pump	20 L/min	18 L/min	18 L/min
	Hydraulic pressure of pilot pump	3.9 Mpa	3.5 Mpa	3.5 Mpa
PERFORMANCE	Swing speed	11 rpm	11.2 rpm	11.2 rpm
	Travel Speed	5.3-3.2 km/h	5.3-3.5 km/h	5.3-3.5 km/h
	Gradeability	35 °	30 °	30 °
	Ground Pressure	36.8 kPa	40.7 kPa	42 kPa
TANK CAPACITY	Fuel Tank Capacity	245 L	180 L	180 L
	Hydraulic Oil Tank Capacity		150 L	
TRACK		600 mm steel track		
		700 mm steel track		
		800 mm steel track		

DIMENSIONS

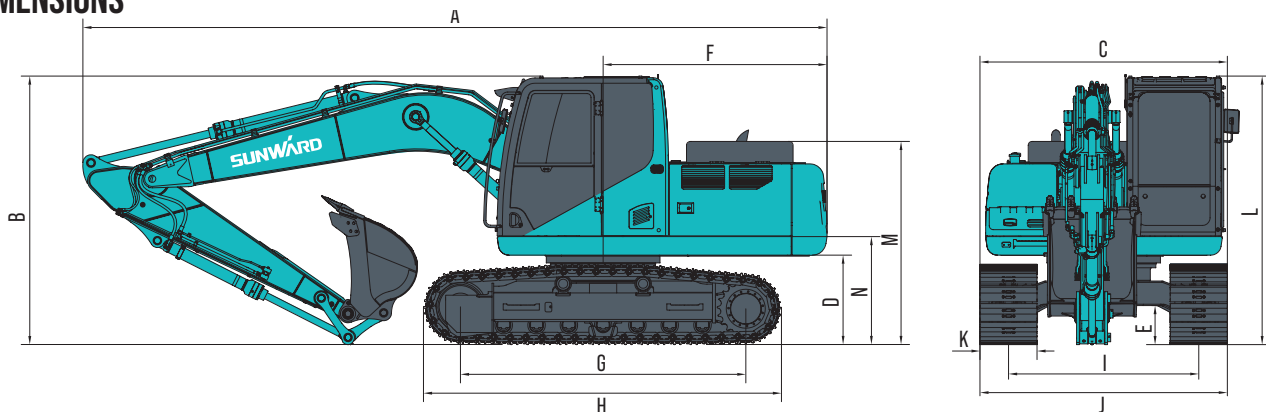

WORKING RANGE

		SWE 155F	SWE 155UF	SWE 155UF-2PB	
WORKING RANGE & BREAKOUT FORCE	a	Max. cutting height	8 640 mm	8 700 mm	9 645 mm
	b	Max. loading height	6 145 mm	6 200 mm	7 140 mm
	c	Max. digging depth	5 525 mm	5 525 mm	5 600 mm
	d	Max. digging depth (2.4 m)	5 320 mm	5 326 mm	5 490 mm
	e	Max. vertical digging depth	4 930 mm	5 140 mm	4 635 mm
	f	Max. digging reach	8 330 mm	8 370 mm	8 490 mm
	g	Max. reach on ground	8 150 mm	8 225 mm	8 345 mm
	h	Min. front swing radius	2 530 mm	2 640 mm	2 095 mm
	i	Max dozer lifting height	532 mm	540 mm	540 mm
	j	Max dozer cutting depth	628 mm	625 mm	625 mm
		Max digging force (Bucket)	100 kN	100 kN	100 kN
		Max digging force (Arm)	76 kN	76 kN	76 kN

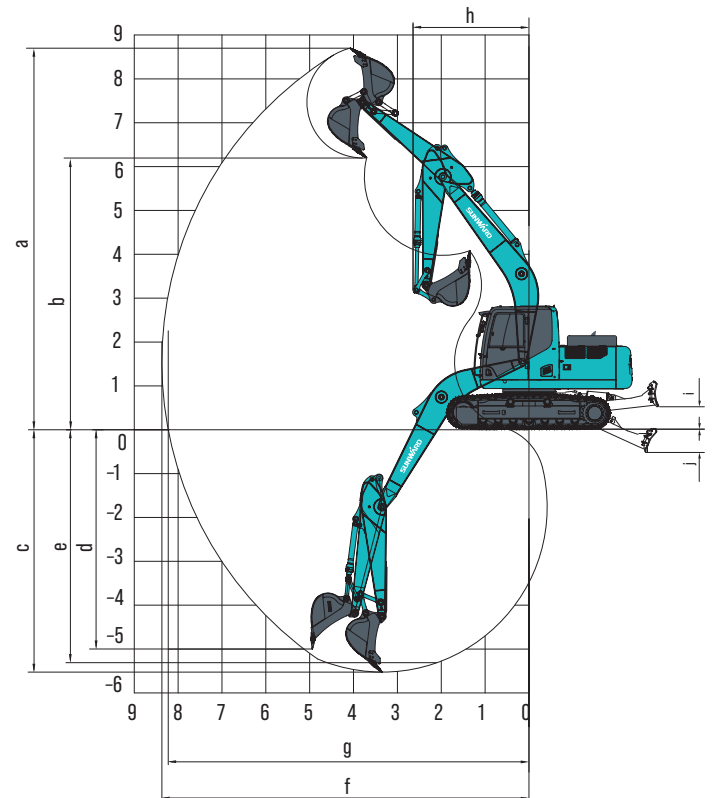

Sunward has one or more dealers
in each of these  countries.

Please check our website for our current list of dealers.

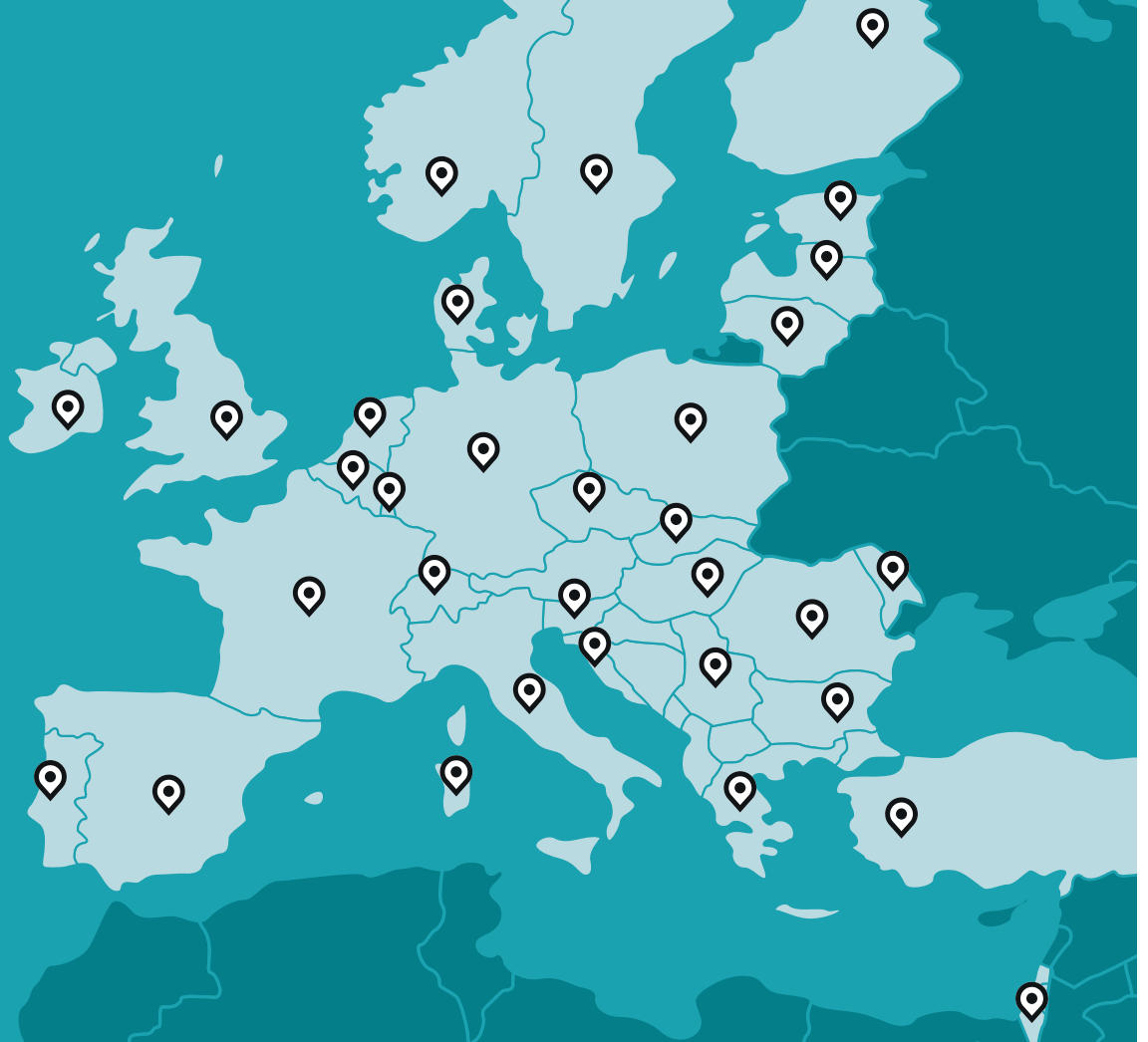

SUNWARD EUROPE HEAVY INDUSTRY N.V

✉ Havenlaan 1
B-3980 TESSENDERLO
Belgium

☎ +32 (0) 11 43 46 66
▶ info.eu@sunward.cc
🌐 www.sunward.eu

DEALER CONTACTS

Simmler *Vermietung
Verkauf
Reparatur*
Baumaschinen

Buechstr. 25, 8645 Jona 055 212 69 50
www.simmler.swiss