

Technical Parameters and Dimensions

ITEM		UNIT	PARAMETERS	
Main performance parameters	Max rated lifting capacity	t	10	
	Min rated range	m	2.5	
	Turntable tail swing radius	mm	2750	
	Maximum load moment	Basic boom	KN.m	333
		Full extensional main boom	KN.m	156
	Lifting height	Basic boom	m	7
		Full extensional main boom	m	21.5
		Full extensional boom + jib	m	26
	Boom length	Basic boom	m	6.8
		Full extensional main boom	m	21.2
Full extensional boom + jib		m	21.2+5	
	Installation angle of jib	°	0、15、30、45	
Dimensions	Overall length	mm	9073	
	Overall width (extension/retraction)	mm	2800	
	Overall height	mm	3070	
	Machine weight	t	20.5	
Travel	Speed	km/h	2.7/4.1	
	Minimum ground clearance of frame	mm	478	
	Max gradeability	%	40	
	Ground pressure	Mpa	0.05	
Operating speed	Maximum speed of hoisting single rope (no load)	m/min	115	
	Boom telescopic time (extension/retraction)	S	20/33	
	Boom luffing time (up/down)	S	12/16	
	Swing speed	r/min	3	
Engine	Brand	/	Cummins	
	Models	/	QSB6.7	
	Type	/	Direct injection, four-stroke, turbocharged, inter-cooling	
	Displacement	L	6.7	
	Power	Kw	129	
	Rotation speed	r/min	2200	
	Capacity of hydraulic oil tank	L	280	
	Capacity of fuel tank	L	380	



Main Technical Characteristics

Main Technical Features of SWTC10 Track Crane:

- Cummins engines, meet the Euro V emission standards;
- Lightweight high-strength steel with decagonal section, four telescopic main arms and one truss jib;
- Standard Hirschmann force limiter system, CAN bus control, overload lifting, overwinding and overwinding protection, real-time monitoring of operation status to ensure operation safety;
- Constant power load-sensitive hydraulic control system is adopted, which is stable and reliable, with imported key components, centralized layout and easy maintenance;

- The diameter of the raceway of the slewing bearing is increased and the performance is improved. The flange seat ring adopts an integral ring forging structure to avoid stress concentration and improve durability;
- Equipped with grease - lubricated sealed track chain with long service life and no maintenance. And the truck frame is designed with double bevels to prevent accumulation of foreign matters.



Note: The parameters above are subject to the data after the type test

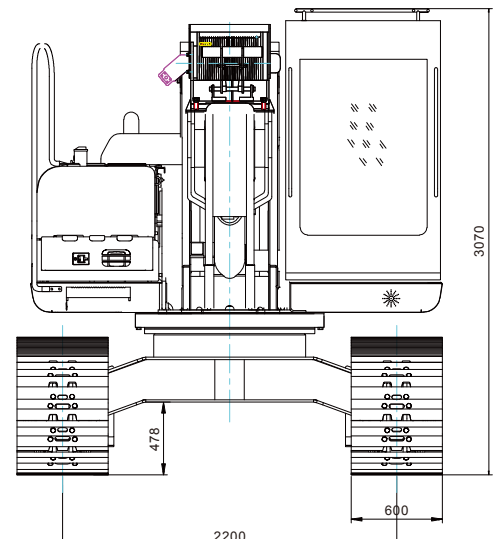
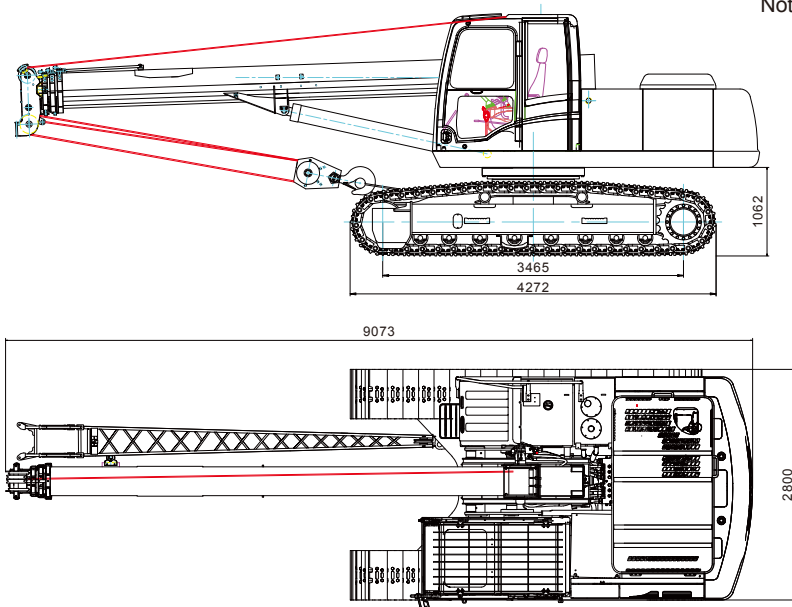

SWTC10 Rated Total Lifting Weight for Telescopic Boom Track Crane (Unit: kg)

Working range (unit: m)	Length of main arm (unit: m)						Working angle (°)	Main arm + jib (unit: m)			
								21.2+5			
	6.8	9.68	12.56	15.44	18.32	21.2		0°	15°	30°	45°
2.5	10000	8000	6000				78	1050	850	600	480
3	10000	8000	6000	4200			76	1000	800	590	470
3.5	9000	8000	5800	4200	3500		74	970	780	570	450
4	8000	7000	5700	4000	3500	3000	72	950	750	550	430
4.5	7400	6500	5000	3800	3400	3000	70	920	720	520	410
5	6000	5500	4500	3500	3100	2900	68	900	680	490	390
5.5	5000	4500	3700	3100	2800	2700	66	860	650	460	370
6	4000	4000	3500	2800	2500	2350	64	810	620	430	350
6.5		3500	3000	2500	2300	2150	62	760	590	400	330
7		3000	2800	2300	2100	1980	60	700	560	370	300
7.5		2600	2500	2150	1900	1830	58	650	520	340	280
8		2450	2250	2000	1750	1700	56	610	490	310	240
9			2000	1780	1560	1510	54	570	450	270	210
10			1850	1600	1410	1350	52	520	410	230	170
11			1650	1400	1280	1230	50	470	370	190	130
12				1280	1160	1110	48	420	320	150	
13				1150	1060	1020	46	360	260		
14				1050	990	930	44	290	200		
15					900	860	42	210			
16					800	780					
17					700	680					
18						600					
19						500					
Parts of line	7	6	5	4	3	2	Parts of line	1			
Traveling on load	75%	65%		50%		Not allowed	Traveling on load	Not allowed			
Weight of lifting hook	116kg						Weight of lifting hook	48kg			

- Notes:
- The value given in the table is the rated lifting weight of the crane, including the weight of the hook, under the condition of solid and smooth ground;
 - The actual lifting weight is the rated lifting weight shown in the above table minus the weight of lifting appliances such as lifting hooks;
 - The working range in the table refers to the actual range after lifting;
 - The whole machine shall be horizontal and the working slope shall not be more than 5%. The traveling speed shall not be greater than the minimum speed;
 - When the actual boom length and the working range are both between two values, the weight should be determined according to the larger ones;
 - When climbing the slope, the main arm is retracted and placed at the minimum angle, and the counterweight is placed in the uphill direction.

SWTC10 crane lifting height and working range

