

# E95

**900 KG  
1984 LBS**

**IT** Unico sul mercato, il Traker E95 è il modello dalle prestazioni e caratteristiche senza eguali. Trasportare fino a 900 kg di materiale non è mai stato così facile. La doppia pompa a portata variabile con mono-joystick rende questa macchina potente e facile da governare, riduce i consumi ed azzerava gli interventi di manutenzione. Il mezzo ideale per grandi carichi di lavoro e flotte noleggio.

**EN** Unique of its kind, E95 minidumper has performances and features like no other. It's never been easier to carry up to 1984 lbs of material. The double variable-displacement pump with mono-joystick hydraulic control makes this machine powerful and easy-to-use, reducing consumption and eliminating maintenance. It's the ideal dumper for high-duty activities and rental fleets.

E95 • ELECTRIC MINIDUMPER

CNF—CONSTRUCTION EQUIPMENT



Sottocarri rinforzato  
Heavy duty undercarriage



Cofano posteriore con apertura laterale  
per facilitare gli interventi di manutenzione  
Engine cover with side opening to facilitate maintenance

5



Versioni disponibili · Available models

1

Due pompe port. var. + 1 pompa ingr.  
Two var. displ. pumps + 1 gear pump

2

Trasmissione idrostatica  
Hydrostatic transmission

3

Rulli oscillanti  
Rocking rollers

VANTAGGI / ADVANTAGES

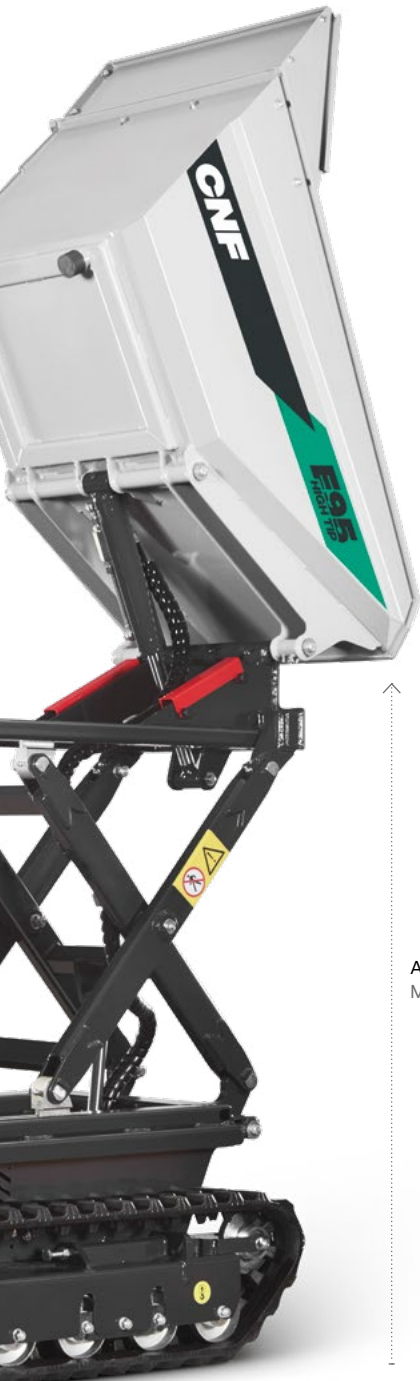

Cassone con sponde apribili  
Farm bed skip



Altezza max 1420 mm  
Max height 55.9 inch



Pedana ammortizzata  
Soften foot-plate

# E95

MINIDUMPER

CAPACITÀ OPERATIVA  
OPERATING WEIGHT  
**900 KG · 1984 LBS**

LARGHEZZA AI CINGOLI  
TRACK WIDTH  
**780 MM · 27.9 INCH**

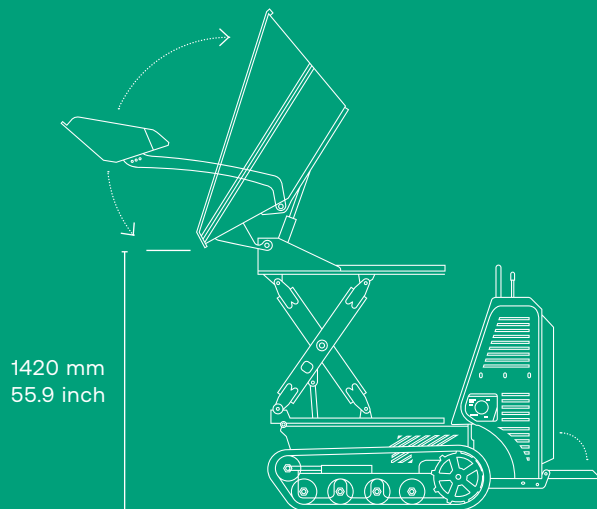
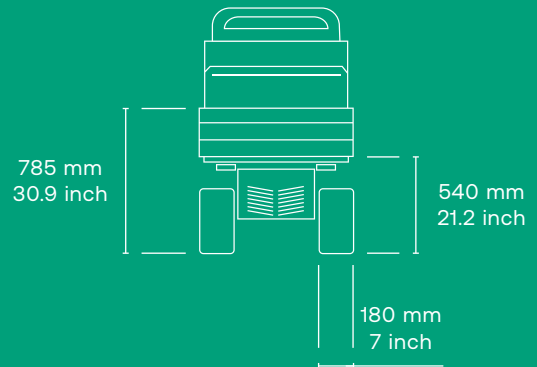
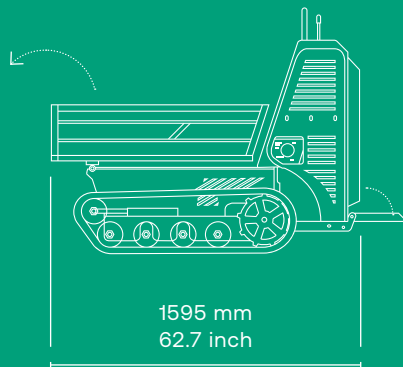
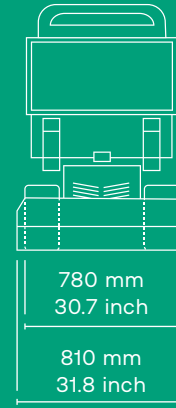
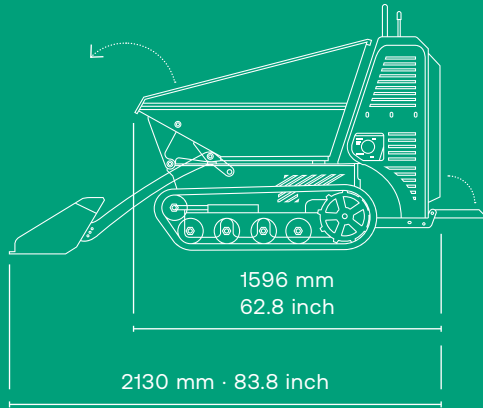

**VOLTAGGIO BATTERIA****BATTERY VOLTAGE**

→ 80 V

**TRASMISSIONE****TRANSMISSION**→ IDROSTATICA  
→ HYDROSTATIC**CAPACITÀ BATTERIA****BATTERY CAPACITY**

→ 80 KWH

**MOTORE IDRAULICO****HYDRAULIC MOTOR**2 x ORBITALI  
2 x ORBITAL**PORTATA POMPA****PUMP FLOW RATE**→ 2x32 L/MIN + 1 POMPA INGR  
→ 2x8.5 GPM + 1 GEAR PUMP**PRESSIONE MASSIMA****MAX PRESSURE**

180 bar

**TEMPO DI RICARICA****BATTERY VOLTAGE**

80 V

**LARGHEZZA CINGOLI****TRACK WIDTH**180 mm  
7 inch**RULLI****TRACK ROLLERS**

→ 4

**RULLI OSCILLANTI****ROCKING ROLLERS**SI  
YES**REGOLAZIONE CINGOLI****TRACK TENSIONER**SI  
YES**VELOCITÀ MASSIMA****MAX SPEED**4 km/h  
2.5 mph**CAPACITÀ OPERATIVA****OPERATING WEIGHT**

→ 900 KG / 1984 LBS

**HIGH-TIP**

→ 800 KG / 1763 LBS

**MASSA A VUOTO****EMPTY WEIGHT**500 kg  
1102 lbs**CONTROLLO****CONTROL**

→ MONOJOYSTICK

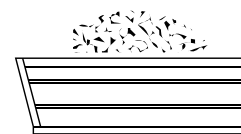
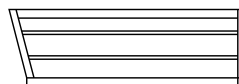
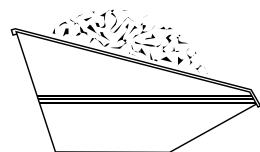
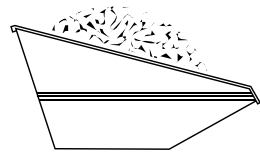
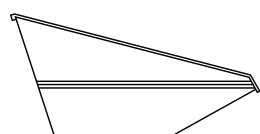
**CARATTERISTICHE TECNICHE / TECHNICAL FEATURES** RASO 0.30 m<sup>3</sup>  
STRUCK 0.39 yd<sup>3</sup> COLMO 0.36 m<sup>3</sup>  
HEAPED 0.45 yd<sup>3</sup> RASO 0.17 m<sup>3</sup>  
STRUCK 0.22 yd<sup>3</sup> COLMO 0.25 m<sup>3</sup>  
HEAPED 0.32 yd<sup>3</sup> RASO 0.28 m<sup>3</sup>  
STRUCK 0.37 yd<sup>3</sup> COLMO 0.36 m<sup>3</sup>  
HEAPED 0.47 yd<sup>3</sup>**CAPACITÀ / CAPACITY**